



Construction Specification for Civil Works

C213 - Earthworks

TABLE OF CONTENTS

CLAUSE	CONTENTS	PAGE
	ORIGIN OF DOCUMENT, COPYRIGHT	3
	REVISIONS: C213 – EARTHWORKS	3
	GENERAL	4
C213.01	SCOPE	4
C213.02	DEFINITIONS	4
C213.03	REFERENCES	4
C213.04	EARTHWORKS MATERIALS	5
C213.05	PROTECTION OF EARTHWORKS	6
C213.06	STOCKPILE SITES	6
	REMOVAL OF TOPSOIL	8
C213.07	SCOPE	8
C213.08	TOPSOIL STOCKPILES	8
	CUTTINGS	9
C213.09	SCOPE	9
C213.10	EXCAVATION	9
C213.11	BATTER TOLERANCES	9
C213.12	BENCHING IN CUTTINGS	10
C213.13	TREATMENT OF FLOORS OF CUTTINGS	10
C213.14	TRANSITION FROM CUT TO FILL	11
	BLASTING	11
	UNSUITABLE MATERIAL	12
C213.15	GENERAL	12
	EMBANKMENT CONSTRUCTION	13
C213.16	SCOPE	13

C213.17	EMBANKMENT MATERIAL.....	13
C213.18	FOUNDATIONS FOR EMBANKMENTS.....	13
C213.19	HILLSIDE EMBANKMENTS	14
C213.20	PLACING FILL FOR EMBANKMENT CONSTRUCTION.....	14
C213.21	EMBANKMENT BATTERS	15
C213.22	ROCK FACING OF EMBANKMENTS.....	15
C213.23	TRIMMING TOPS OF EMBANKMENTS.....	16
C213.24	SELECTED MATERIAL ZONE (SMZ).....	16
C213.25	FILL ADJACENT TO STRUCTURES	17
C213.26	TREATMENT AT WEEPHOLES.....	18
C213.27	FILL ADJACENT TO DRAINAGE AND BRIDGE STRUCUTRES	18
C213.28	SPOIL.....	20
C213.29	BORROW.....	20
COMPACTION AND QUALITY CONTROL.....		21
C213.30	COMPACTION AND MOISTURE REQUIREMENTS.....	21
C213.31	TEST LOCATIONS.....	22
C213.32	WIDENING OF FORMATION	22
LIMITS AND TOLERANCES.....		23
ANNEXURE C213A EARTHWORKS - PROJECT SPECIFIC INFORMATION		24
ANNEXURE C213B SETTING OUT OF EARTHWORKS.....		25

ORIGIN OF DOCUMENT, COPYRIGHT

This document was originally based on AUS-SPEC - Development Construction Specification C213 - Earthworks. Substantial parts of the original AUS-SPEC document have been deleted and replaced in the production of this Tamworth Regional Council Construction Specification for Civil Works. The parts of the AUS-SPEC document that remain are still subject to the original copyright.

This document has been developed for use with the construction of civil works within the Tamworth Regional Council local government area.

This is not a controlled document. A full copy of the latest version of this document can be found on the Tamworth Regional Council Internet website: http://www.tamworth.nsw.gov.au/construction_specifications

REVISIONS: C213 – EARTHWORKS

REVISIONS	CLAUSES AMENDED	AMENDMENT DETAILS	DATE
1		Original Issue	20/05/2019
2	213.30	Amendment to standard compaction	01/05/2023

This Specification includes a series of Annexures that detail Project Specific Requirements

GENERAL

C213.01 SCOPE

Scope

The work to be executed under this Specification consists of:

- (a) removal of topsoil.
- (b) all activities and quality requirements associated with site regrading, the excavation of cuttings, the haulage of material and the construction of embankments to the extent defined in the approved drawings and specification.
- (c) preparation and treatment of subgrade materials (ie: cutting floors and foundations for embankments)
- (c) removal and replacement of any unsuitable material.
- (d) any spoil or borrow activities associated with earthworks.
- (e) any additional processing of selected material for the selected material zone.

C213.02 DEFINITIONS

The Works – Defined as follows:

The Works

- **Developer Infrastructure Works** - work includes subdivisions and any public infrastructure work associated with an approved Development in the TRC local government area requiring a construction certificate.
- **Contracted Works** – infrastructure work undertaken by a Principal Contractor or subcontractor formally appointed by TRC and supervised by TRC.
- **Internal Works** - infrastructure work undertaken by TRC’s day labour workforce.

Constructor – Defined as the organisation responsible for construction of the Works and the Principal Contractor as defined in the *Work Health and Safety Act 2011*.

Constructor

TRC Representative – Defined as follows:

TRC Representative

- **Developer Infrastructure Works** – Nominated TRC officer(s) for the approved Development.
- **For Contracted Works** – the Superintendent.
- **For Internal Works** – TRC Asset Owner

Constructor’s Representative – Defined as follows:

Constructor’s Representative

- **Contracted Works** – the Principal Contractor’s nominated representative as per the relevant contract.
- **Internal Works** – TRC officer responsible for delivery.

Developer’s Representative– Defined as the person or organisation appointed by the Developer to administer the Constructor responsible for the delivery of **Developer Infrastructure Works**.

Developer’s Representative

C213.03 REFERENCES

Documents referenced in this Specification are listed in full below whilst being cited in the text in the abbreviated form or code indicated.

Documents Standards Test Methods

Where not otherwise specified in the relevant Specifications or the approved design drawings, the Constructor shall use the latest versions of the Reference documentation, including amendments and supplements, listed in the Specifications at the time of the Works approval.

Currency

(a) Tamworth Regional Council (TRC) Specifications

C211 - Control of Erosion and Sedimentation.

C212 - Clearing and Grubbing.

C221 – Pipe Drainage.

C241 – Stabilisation.

C273 – Landscaping.

(b) Australian Standards

References in this Specification or on the approved design drawings to Australian Standards are noted by their prefix AS or AS/NZS.

- AS 1289.3.3.1 - Calculation of the plasticity index of a soil.
- AS 1289.5.1.1 - Determination of the dry density/moisture content relation of a soil using standard compactive effort.
- AS 1289.5.4.1 - Compaction control test - Dry density ratio, moisture variation and moisture ratio.
- AS 1289.5.7.1 - Compaction Control Test (Rapid Method).
- AS 1289.6.1.1 - Determination of the California Bearing Ratio of a soil - Standard laboratory method for a remoulded specimen
- AS 3798 - Guidelines on Earthworks for Commercial and Residential Developments.

(c) Legislation

Environmental Planning and Assessment Act 1979 (EP&A Act)

(d) TRC Standard Drawings Applicable to this Section

RD001 - Typical Rural Cross Section.

RD002 - Typical Urban Cross Section.

Where any TRC Standard Drawings conflicts with this Specification, the requirements of this Specification shall take precedence. Proposals to deviate from this Specification shall constitute a **HOLD POINT**.

Precedence

Hold Point

All proposed deviations from the approved design drawings, TRC Standard Drawings, this Specification or the documents referenced within it, shall be submitted for approval to the TRC Representative with supporting evidence at least five (5) working days prior to the work being undertaken.

Process Held: The lot or element affected by the proposed deviation

Hold Point

C213.04 EARTHWORKS MATERIALS

(a) Earthworks Materials

The Constructor shall be responsible for any assumptions made by the Constructor in relation to the nature and types of the materials encountered in excavations and the bulking and compaction characteristics of materials incorporated in embankments.

**Material
Characteristics**

The estimated quantity for general earthworks at any cutting includes all types of materials which may be encountered in the cutting.

Where material from excavations is acceptable for use in embankments, but the Constructor elects to:

- (a) Spoil it, or
- (b) Use it for the Constructor's own purposes, or
- (c) Use it as a source of pavement materials, or
- (d) Construct embankments with dimensions in excess of those specified

and a deficiency of material for embankment construction is thereby created, the Constructor shall make good that deficiency from sources of material meeting the quality requirements specified in Clause C213.18. The cost of making good such deficiency of material shall be borne by the Constructor.

**Material
Deficiency**

**Constructor's
Cost**

C213.05 PROTECTION OF EARTHWORKS

The Constructor's responsibility for care of the Works shall include the protection of earthworks.

**Constructor's
Responsibility**

The Constructor shall install effective erosion and sedimentation control measures in accordance with *C211 - Control of Erosion and Sedimentation*, prior to commencing earthworks, and shall maintain these control measures for the duration of the Works and until all work is suitably protected by revegetation or permanent control measures.

**Erosion and
Sedimentation
Control**

Adequate drainage of all working areas shall be maintained throughout the period of construction to ensure run-off of water without ponding, except where ponding forms part of a planned erosion and sedimentation control system. In salt affected areas, the Constructor shall take adequate precautions to minimise ingress of surface water into the groundwater table.

**Drainage of
Working Areas /
Salinity
Prevention**

When rain is likely or when work is not proposed to continue in a working area on the following day, precautions shall be taken to minimise ingress of any excess water into earthworks material. Ripped material remaining in cuttings and material placed on embankments shall be sealed off by adequate compaction to provide a smooth tight surface.

**Wet Weather
Precautions**

Should insitu or stockpiled material become over wet as a result of the Constructor not providing adequate protection of earthworks, the Constructor shall be responsible for replacing and/or drying out the material and for any consequent delays to the operations.

Wet Material

C213.06 STOCKPILE SITES

The Constructor shall only use nominated stockpile sites. Alternative stockpile locations may be nominated to the TRC Representative and/or the Developer's Representative (for Developer Infrastructure Works) provided all appropriate approvals and clearances accompany the request. Particular reference to the Works Approval and Environmental Assessments are required. If approved, alternative stockpile locations shall be incorporated into the Erosion and Sedimentation Control Plan (ESCP).

**Additional
Stockpile Sites**

Hold Point

Alternative stockpile locations shall be nominated to the TRC Representative and/or the Developer's Representative (for Developer Infrastructure Works), five (5) working days prior, with appropriate detail confirming the extent of the stockpile(s) and the relevant approvals and clearances applicable to the area nominated.

Hold Point

Process Held: Preparation and Use of Alternative Stockpile Sites

Any clearing and grubbing required for these sites shall be carried out in accordance with *C212 - Clearing and Grubbing*. Temporary erosion and sedimentation control measures shall be taken in accordance with *C211 - Control of Erosion and Sedimentation*.

***Clearing and
Grubbing***

Restoration of stockpile sites following completion of the work shall be carried out in accordance with *C273 - Landscaping*.

Restoration

REMOVAL OF TOPSOIL

C213.07 SCOPE

Topsoil is surface soil which is reasonably free from subsoil, refuse, clay lumps and stones.

Definition

Removal of topsoil from any section of work shall only commence after erosion and sedimentation controls have been implemented and when clearing, grubbing and disposal of materials have been completed on that section of work in accordance with C211 - *Control of Erosion and Sedimentation*.

Prerequisites

Topsoil from the Works site shall be removed and stockpiled separately clear of the work zone with care taken to avoid contamination by other materials. The work shall include the following:-

Extent of Work

(a) Cuttings

Removal of the topsoil to a depth quoted in **Annexure C213A**.

**Topsoil Removal
- Cuttings**

(b) Embankments

Removal of topsoil over the base of embankments up to the depth below the natural surface quoted in **Annexure C213A**. For those embankments or sections of embankment where the height of embankment from natural surface to underside of pavement is less than two metres, topsoil which is deeper than the depth quoted in **Annexure C213A** shall be removed to its full depth.

**Topsoil Removal
- Embankments**

C213.08 TOPSOIL STOCKPILES

The maximum height of stockpiles shall not exceed 2.5m and the maximum batter slope shall not exceed 2H:1V.

Height and Batter

Topsoil stockpiles shall not contain any timber or other rubbish and shall be trimmed to a regular shape.

**Stockpiles
Trimmed**

To minimise erosion, stockpile batters shall be track rolled or stabilised by other means acceptable to the TRC Representative and/or the Developer's Representative (for Developer Infrastructure Works).

Erosion Control

Where seeding of stockpiles to encourage vegetation cover is specified, such work shall be carried out in accordance with C273 – *Landscaping*.

**Seeding
Stockpile**

CUTTINGS

C213.09 SCOPE

Construction of cuttings shall include all operations associated with the excavation of material within the limits of the batters as shown on the approved drawings including benching, treatment of cutting floors, cleaning of batters and transition from cut to fill.

Extent of Work

C213.10 EXCAVATION

Materials encountered in cuttings shall be loosened and broken down as required so that they are acceptable for incorporation in the Works.

Cuttings shall have batter slopes as shown on the approved design drawings. If the Constructor proposes to amend the batter slope, a submission is to be made to the TRC Representative provided that the amended slope has been reviewed and approved by a Geotechnical Engineer and the Design Engineer for the Works. The suitability of batter treatments shall also be reviewed.

Batter Slopes

The tops of all cuttings shall be neatly "rounded" to the dimensions shown on the approved design drawings unless otherwise directed.

Batters to be Even

In all cuttings, undulations in the general plane of the batter shall not be permitted except that batters may require progressive flattening at the ends of cuttings due to the presence of less stable material.

Unstable Material

Cut faces shall be cleaned of loose or unstable material progressively as the excavation proceeds.

Where, after the removal of topsoil as specified in Clause C213.07, material of variable quality or moisture content is encountered, the Constructor shall adjust the excavation methods to ensure blending of the materials, to obtain material meeting the requirements of Clause C213.17.

Blending Material

C213.11 BATTER TOLERANCES

The tolerances for the excavation of batters, measured at right angles to the design grade line, shall be $\pm 300\text{mm}$. Batters must not have undulations in the general plane of the batter.

Batter Tolerances

If the Constructor excavates the batter beyond the batter slope line and the tolerance applicable thereto, the TRC Representative may authorise a change in the general slope of the batter to suit the convenience of the Constructor, but such a change shall not be regarded as a redetermination of the batter slope under Clause C213.10.

Excavation beyond Batter Line

The cost of any increase in excavation quantities resulting from such change in batter slope shall be borne by the Constructor. Alternatively, the Constructor shall submit details of the material and/or methods proposed to restore the specified slope and stability of the batter for the TRC Representative's approval.

Constructor's Cost

For batters steeper than 1:1, if any section of the batter up to a height of 3m above the table drain level has been over excavated beyond the tolerance limit specified, the TRC Representative may direct that the batter be restored to the average batter slope using randomly mortared stone. The stone shall be similar to the sound rock in the cutting and the mortar shall be coloured to match the colour of the rock.

Restoration of Batter Slope

The cost of restoring batters shall be borne by the Constructor.

Constructor's Cost

C213.12 BENCHING IN CUTTINGS

Cut batters shall be benched as shown on the approved design drawings to provide drainage and erosion control. Notwithstanding the tolerances permitted under Clause C213.11, bench widths shall not be less than those shown on the approved design drawings to allow access for maintenance purposes.

**Bench
Construction**

Benches shall be maintained and cleaned of loose stones and boulders regularly throughout the construction period and during the Defects Liability Period. The cost of such maintenance and cleaning of benches shall be borne by the Constructor.

**Bench
Maintenance
Constructor's
Cost**

The floor of the bench must not vary from levels shown on the approved design drawings by more than tolerances shown in Clause C213.33.

Bench Floor

C213.13 TREATMENT OF FLOORS OF CUTTINGS

The floors of cuttings shall be excavated, parallel to the designed grade line, to a designed floor level which shall be at the underside of the selected material zone (SMZ) or where there is no SMZ, to the underside of the pavement subbase. The floors shall then be trimmed to a level of not more than 0mm above or 50mm below the designed floor level. Where the TRC Representative and/or the Developer's Representative (for Developer Infrastructure Works) considers that any underlying material is unsuitable for pavement support, the Constructor shall be directed to remove it in accordance with Clause C213.15.

Excavation Level

A typical section for the pavement in cuttings is shown in Figure C213.1 below.

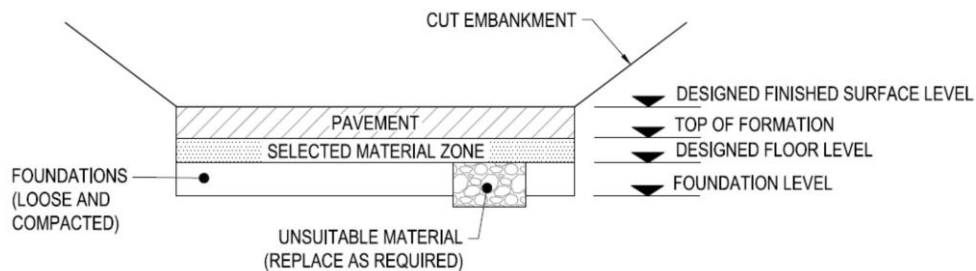

Figure C213.1 – Typical Section in Cuttings

The Constructor shall rip or loosen all material in the floor to a minimum depth of 200mm below the designed floor level for the width of the SMZ (or subbase layer where there is no SMZ). The maximum dimension of any particles in the ripped or loosened zone shall not exceed 150mm.

**Floor Material
Ripped**

Prior to ripping or loosening the cutting floor, the Constructor shall determine the CBR of the material in the floor as per AS 1289.6.1.1. Sufficient tests shall be taken to represent all the various materials which may exist in the cutting floor. If material in the floors of cuttings has a CBR value less than the value quoted in the approved design drawings, the Constructor shall nominate to the TRC Representative a methodology for ensuring the floor design will meet the required criteria.

CBR Testing

Ripped or loosened material shall be made available for inspection by the TRC Representative and/or the Developer's Representative (for Developer Infrastructure Works) before recompaction commences. It shall be recompacted in accordance with Clause C213.30.

**Inspection by the
TRC
Representative
and/or
Developer's
Representative**

After recompaction, the floors of cuttings shall be re-trimmed parallel with the finished surface so that the levels do not vary more than 0mm above or 40mm below the designed floor levels. Conformance survey shall be provided to verify designed floor levels.

Level Tolerances

Prior to placing any subsequent layers over the completed cutting floor, the Constructor shall present the completed surface to the TRC Representative for inspection and proof rolling to be undertaken by the Constructor. The Constructor shall verify as part of the quality system that the completed surface has achieved full conformance with all respects of this Specification.

Inspection by the TRC Representative

Witness Point

Notification shall be given to the TRC Representative no less than two (2) working days prior to the cutting floor being made available for inspection and proof rolling. Records verifying full conformance as per the requirements of this Specification shall be made available on request.

Process Held: Placement of Subsequent Layers.

Witness Point

C213.14 TRANSITION FROM CUT TO FILL

After the removal of topsoil and before the excavation of any cutting commences, the Constructor shall survey and mark the position of the intersection line between cutting and embankment occurring at the underside of the SMZ or pavement subbase.

Intersection Line

Following excavation to the cutting floor, a terrace shall be excavated for the width of the SMZ (or subbase layer where there is no SMZ) to a depth of 600mm below and parallel to the cutting floor, as shown in Figure C213.2.

Terrace Construction

The terrace shall extend into the cut to the point where the cutting floor is 600mm below the original stripped surface, or a distance of 20 metres, whichever is the lesser.

Extent of Terrace

The material excavated shall be either incorporated in the embankments or spoiled as directed by the TRC Representative and/or the Developer's Representative (for Developer Infrastructure Works). Material incorporated in embankments shall be included in the excavated volume for general earthworks and material spoiled shall be included in the excavated volume of Unsuitable Material to Spoil.

Excavated Quantity

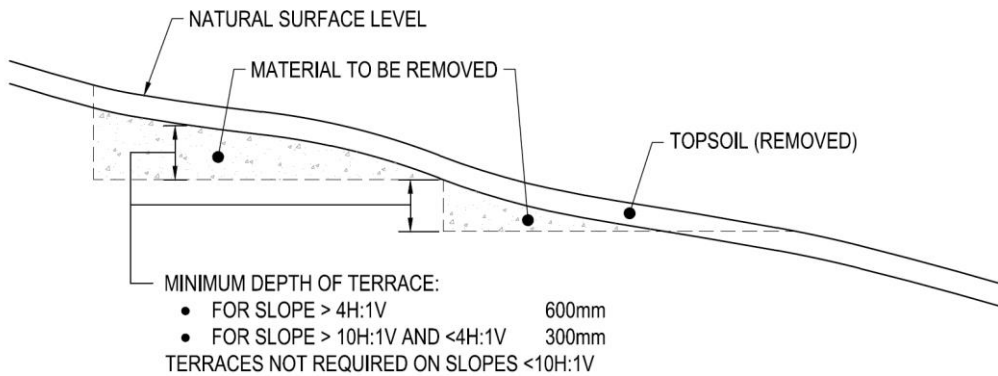

Figure C213.2 – Transition from Cut to Fill

The material placed above the terrace shall satisfy the requirements of Clause C213.17 and shall be compacted in accordance with Clause C213.309.

Quality and Compaction

BLASTING

Under no circumstances shall blasting be undertaken.

No blasting

UNSUITABLE MATERIAL

C213.15 GENERAL

Unsuitable material is that occurring below the designed floor level of cuttings and below the nominated depth for stripping topsoil beneath embankments, which the TRC Representative and/or the Developer's Representative (for Developer Infrastructure Works) deems to be unsuitable for embankment or pavement support in its present state. Unsuitable material also includes material in cuttings which the TRC Representative and/or the Developer's Representative (for Developer Infrastructure Works) deems to be unsuitable for embankment construction.

Definition

Such material shall be excavated to the extent directed by the TRC Representative and/or the Developer's Representative (for Developer Infrastructure Works). Material removed as unsuitable, as directed by the TRC Representative and/or the Developer's Representative (for Developer Infrastructure Works), shall be spoiled in accordance with Clause C213.28.

Extent of Excavation

After removal of the unsuitable material, the floor of the excavation shall be re-presented to the TRC Representative and/or the Developer's Representative (for Developer Infrastructure Works) for inspection, prior to backfilling with replacement material, to determine whether a sufficient depth of unsuitable material has been removed. Prior to placing replacement material the excavated surface shall be compacted in accordance with Clause C213.30.

Floor Inspection

Hold Point

Notification shall be given to the TRC Representative and/or the Developer's Representative (for Developer Infrastructure Works) where it is deemed that unsuitable material may exist. Notification shall be made as soon as the unsuitable material is encountered to facilitate inspections and subsequent removal where directed.

Hold Point

Process Held: Removal and Replacement of Unsuitable Material.

The unsuitable material which has been removed shall be replaced with material from cuttings, or with material borrowed in accordance with Clause C213.29, of the quality specified in Clause C213.17. Replacement material is deemed to form part of embankment construction. It shall be placed in accordance with Clause C213.20 and compacted in accordance with Clause C213.30.

Replacement Material

All costs associated with reworking or replacing any material which the TRC Representative and/or the Developer's Representative (for Developer Infrastructure Works) deems to have become unsuitable because of inappropriate construction activities shall be borne by the Constructor.

Constructor's Costs

Examples of inappropriate construction activities include poor surface drainage, restricted or inoperative subsurface drains, contamination, excessive sized construction plant where the imposed load exceeds the material strength, poorly maintained construction plant allowing leakage of oils and water onto the formation, and leaving the surface unsealed allowing moisture ingress during wet weather.

Example of Inappropriate Construction Activities

EMBANKMENT CONSTRUCTION

C213.16 SCOPE

Embankment construction includes all operations associated with the preparation of the foundation areas on which fill material is to be:

Extent of Work

- Placed;
- The placing and compacting of approved material within areas from which unsuitable material has been removed in accordance with Clause C213.15;
- The placing and compacting of fill material and of materials of specified quality in nominated zones throughout the Works; and
- All other activities required to produce embankments as specified to the alignment, grading and dimensions shown on the approved design drawings.

It also includes any pretreatment such as breaking down or blending material or drying out material containing excess moisture.

C213.17 EMBANKMENT MATERIAL

Material for embankment construction shall be obtained from the cuttings within the Works site in accordance with Clause C213.10, supplemented by borrow material in accordance with Clause C213.29 and from other sources as specified in the approved design drawings. The material shall be free of tree stumps, roots, topsoil, steel, organic material and other contaminants and shall be capable of being compacted in accordance with Clause C213.30.

Location and Quality

The work shall be programmed so that material of the quality specified in Clause C213.20 and C213.24 for the upper zones of the formation is available when required.

Selection of Material

C213.18 FOUNDATIONS FOR EMBANKMENTS

Following removal of topsoil in accordance with Clause C213.07, the embankment foundation area shall be made available for inspection and proof rolling.

Inspection

Prior to placing any subsequent layers over the completed embankment foundation, the Constructor shall present the completed surface to the TRC Representative for inspection and proof rolling by the Constructor.

A typical section for the pavement for embankments (in fill) is shown in Figure C213.3 below.

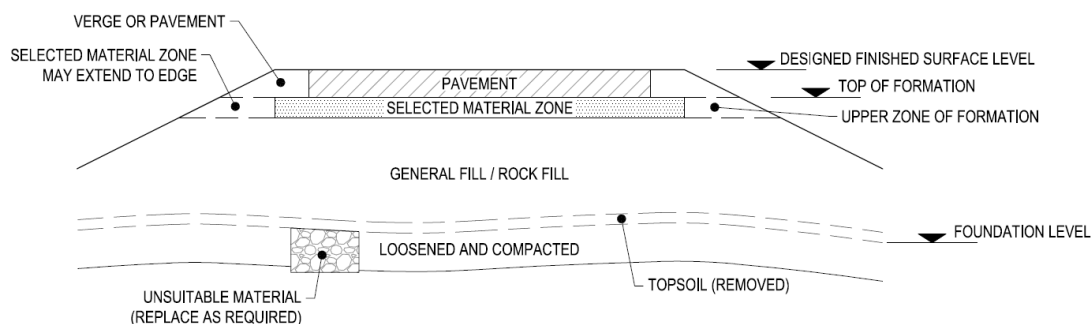

Figure C213.3 – Typical Sections for Embankments

Where the TRC Representative and/or the Developer's Representative (for Developer Infrastructure Works) considers that any underlying material is unsuitable, the TRC Representative and/or the Developer's Representative (for Developer Infrastructure Works) may direct that it be removed and replaced in accordance with Clause C213.15.

Unsuitable Material

Witness Point

Notification shall be given to the TRC Representative when the topsoil has been removed and the embankment foundation is ready for inspection and proof rolling.

Process Held: Preparation of Embankment Foundation.

Witness Point

(a) Foundations for Shallow Embankments

Shallow embankments are those embankments of a depth less than 1m from the top of pavement to natural surface. After removal of topsoil, the Constructor shall survey and work out the extent of the area of shallow embankments.

Shallow Embankments

Material in the foundations for shallow embankments which does not meet the requirements specified in **Annexure C213A** shall be deemed unsuitable in accordance with Clause C213.15 and shall be replaced by material of the specified quality.

Unsuitable Material

Foundations for shallow embankments shall be prepared for embankment construction after removing topsoil and unsuitable material, by loosening the material exposed to a depth of 200mm, adjusting the moisture content of the loosened material and compacting as specified in Clause C213.30. The Constructor shall use equipment and techniques to minimise surface heaving or other foundation damage.

Preparation of Foundations

b) Other Embankments

For all other embankments the foundation shall be prepared by grading and levelling the general area, adjusting the moisture content where necessary and compacting the top 200mm as specified in Clause C213.30.

Preparation

Where a bridging layer has been specified as a foundation treatment in the approved design drawings. The bridging layer shall consist of free-draining granular material with or without geofabric interlayer as specified on the approved design drawings. The granular material shall be end-dumped and spread in a single layer and in sufficient depth to allow the passage of earthmoving equipment with minimal surface heaving. The compaction requirements of Clause C213.30 shall not apply to the bridging layer.

Bridging Layer

A bridging layer may also be employed, subject to the approval of the TRC Representative, where ground water or seepage is encountered in the foundation area or where the Constructor demonstrates that it is impracticable to achieve the degree of compaction specified for the foundation in Clause C213.30. A bridging layer shall not be acceptable if its proximity to the pavement is likely to affect the pavement design.

Seepage from Foundations

C213.19 HILLSIDE EMBANKMENTS

Where embankments are to be constructed on or against any natural slopes or the batters of existing embankments, the existing slope or batter, if it is steeper than 4H to 1V in any direction shall be cut in the form of horizontal terraces over the whole area to be covered by new filling. The existing slope or batter shall be stepped in successive terraces, each at least 1m in width, and the terraces are to be cut progressively as the embankment is placed. Wherever possible, terraces shall coincide with natural discontinuities. Subsoil drainage may be required in some instances. Material thus excavated shall be compacted as part of the new embankment material.

Horizontal Terraces

No account shall be taken of the material removed in terracing when determining the general earthworks excavated volume.

Excavated Volume

C213.20 PLACING FILL FOR EMBANKMENT CONSTRUCTION

The methods of excavation, transport, depositing and spreading of the fill material shall be selected so as to ensure that the placed material is uniformly mixed.

Uniformity of Material

The embankment shall be constructed so as to derive its stability from the adequate compaction of the fine material embedding the large rock pieces rather than mechanical interlock of the rock pieces. The fine material shall be compacted to meet the requirements of Clause C213.30.

**Embankment
Stability**

Fill material for embankment construction shall be placed in layers parallel to the grade line and compacted in accordance with Clause C213.30. The layers shall be of uniform compacted thickness not less than 100mm and not exceeding 200mm, except that where more than 25% by volume of the filling consists of rock with any dimension larger than 150mm, the TRC Representative may approve an increase in the compacted layer thickness, provided that the relative compaction specified in Clause C213.30 is attained.

Layer Thickness

The maximum dimension, measured in any direction, of rock pieces in the fill material for embankment construction shall not exceed two-thirds of the approved compacted layer thickness. Any larger rock pieces shall be reduced in size for incorporation in the embankment layers.

**Maximum Size
Rock Pieces**

Stony patches with insufficient fine material to fill the voids shall be reworked with additional fine material being blended in to achieve a dense, compact layer. The cost of any reworking shall be borne by the Constructor

**Reworking Stony
Patches
Constructor's
Cost**

In placing embankment layers, the Constructor shall use equipment and techniques to avoid surface heaving or other damage to the foundations and underlying embankment layers.

**Equipment
Selection for
Placement**

After compaction, embankment material in the zone(s) below the SMZ (or subbase layer, where there is no SMZ) shall have a CBR value not less than that assumed in approved pavement design.

**General Fill CBR
Value**

For the purpose of this Clause, the CBR value of the material shall be determined by Test Method AS 1289.6.1.1.

Test Methods

The Constructor shall be responsible for determining suitable sources of material and for any processing to satisfy these quality requirements.

**Constructor's
Responsibility**

C213.21 EMBANKMENT BATTERS

The batter slopes shown on the approved design drawings represent the estimated requirements for the expected types of materials, and may be subject to redetermination by the TRC Representative according to the TRC Representative's assessment of the materials encountered.

Batter Slopes

When completed, the average planes of the batters of embankments shall conform to those shown on the approved design drawings. No point on the completed batter shall vary from the specified slope line by more than ± 300 mm when measured at right angles to the grade line. However, in no case shall the edge of the formation at the underside of the pavement be nearer to the roadway than shown on the approved design drawings

Slope Tolerances

Undulations in the general plane of the batter shall not be permitted.

**Slope
Undulations**

C213.22 ROCK FACING OF EMBANKMENTS

Where shown on the approved design drawings, embankment batters (including embankments at bridge abutments) shall be provided with a facing of clean, hard, durable rock.

Extent

The rock facing shall be built up in layers ahead of each layer of filling. Rock may be placed by hand or plant but shall be placed in such a manner that its least dimension is vertical and that mechanical interlock between the larger stones occurs.

**Mechanical
Interlock**

Any rock deposited in the rock facing which has an excess of fine material surrounding

it shall be removed together with the excess fine material and replaced.

The Constructor shall adjust its working methods and programme the work so as to obtain hard and durable rock of the specified dimensions as it is required. The space between larger batter rocks shall be filled with progressively smaller rocks to form a 'graded filter' which prevents the leaching out of fines from the fill material but which does not overfill the voids between larger rocks, or cause the larger rocks to lose contact with one another. Fine material shall not cover the outside of rocks on the face of the batter.

Graded Filter

The Constructor shall exercise extreme caution whilst placing the rock facing. Where embankment material is placed above other roads in use, the outer rock layer shall be placed in such a manner as to prevent spillage down the batter. Rock shall be keyed in at the toe of embankments. The Constructor shall ensure that, under no circumstances, could any rock be dislodged and roll onto any adjacent roadway or track in use.

Caution in Placement

C213.23 TRIMMING TOPS OF EMBANKMENTS

The tops of embankments shall be trimmed parallel to the designed grade line at levels equal to the finished surface level less the thicknesses of pavement courses and the SMZ.

Levels

The tops of embankments at these levels shall be compacted to meet the requirements of Clause C213.30 and trimmed so that they do not vary more than 10mm above or 40mm below the levels as calculated above. Conformance survey shall be provided to verify top of embankment levels.

Tolerances

Prior to placing any subsequent pavement layers over the completed top of embankment filling, the Constructor shall present the completed surface to the TRC Representative for inspection and proof rolling. The Constructor shall verify as part of the quality system that the completed surface has achieved full conformance with all respects of this Specification.

Inspection by the TRC Representative

Witness Point

Notification shall be given to the TRC Representative no less than two (2) working days prior to the top of the embankment being made available for inspection and proof rolling. Records verifying full conformance as per the requirements of this Specification shall be made available on request.

Process Held: Placement of Subsequent Layers.

Witness Point

C213.24 SELECTED MATERIAL ZONE (SMZ)

A SMZ may be indicated on the approved drawings as a zone below the subbase layer and in accordance with the following quality requirements:-

Dimension and Quality

- (a) it shall be free from stone larger than 100mm maximum dimension; and
- (b) the fraction passing the 19.0mm AS sieve shall have a CBR value of not less than that specified in the approved design drawings or Annexure C213A.

The selected material shall be obtained from cuttings excavated from the Works site or from borrow areas as specified in Clause C213.29. If necessary, the Constructor shall use working methods to yield material for the SMZ by breaking down oversize rock or by other means, including processing through a crusher, to ensure that the resulting material conforms to the requirements of this Clause.

Winning Material

The Constructor shall ensure that any material encountered of the quality specified for the SMZ shall be either placed directly in the SMZ or stockpiled for future use by the Constructor in the SMZ until at least sufficient material is reserved to complete the SMZ for the Works. It is the Constructors responsibility to import suitable selected material to make up any shortfall.

Selection of Material

The Constructor shall have no right to monetary compensation or a claim for damages in respect of any loss the Constructor may claim to have suffered by reason of the Constructor's failure to reserve sufficient selected material or by reason of stockpiling material for the SMZ.

Constructor's Cost

The SMZ shall be placed and compacted in layers with the compacted thickness of each layer not exceeding 150mm. Compaction shall be as specified in Clause C213.30.

Layer Thickness

After placement the selected material shall be homogeneous and free from patches containing segregated stone or excess fines. There shall be no areas containing material which does not comply with the specified requirements of this Clause.

Homogeneous Layers

The top of the SMZ shall be compacted and trimmed parallel with the designed grade line at a level equal to the finished surface level minus the thickness of pavement layers adopted unless shown otherwise in the approved design drawings. The tolerances for the trimmed levels are given in **Annexure C213A**. Conformance survey shall be provided to verify top of the SMZ.

Tolerances

Prior to placing any subsequent pavement layers over the completed SMZ surface, the Constructor shall present the completed surface to the TRC Representative for inspection and proof rolling by the Constructor. The Constructor shall verify as part of the quality system that the completed surface has achieved full conformance with all respects of this Specification.

Inspection by the TRC Representative

Witness Point

Notification shall be given to the TRC Representative no less than two (2) working days prior to the top of the SMZ being made available for inspection and proof rolling. Records verifying full conformance as per the requirements of this Specification shall be made available on request.

Witness Point

Process Held: Placement of subsequent pavement layers.

C213.25 FILL ADJACENT TO STRUCTURES

Supply and placement of fill adjacent to structures shall be deemed to be part of general earthworks.

For the purpose of this Clause, structures shall include bridges, precast and cast-in-place box culverts and retaining walls. Fill adjacent to other culverts and drainage structures shall be provided in accordance with the approved design drawings and *C223 - Drainage Structures*. The method of compaction shall be amended to avoid damage to all associated structures. It is the responsibility of the Constructor to rectify any damage caused as a result of compaction.

Structure Types

Prior to any backfilling, all foreign material such as waste concrete and timber from within the excavation shall be removed.

Prior to Backfilling

Fill material for backfilling and granular drainage material must be free of timber and rubbish. Where these materials are imported, the Constructor shall provide the TRC Representative and/or the Developer's Representative (for Developer Infrastructure Works) with the details of the proposed source locations, quantities and types of material before the imported material is delivered to the Works site.

Backfill Material

The chemical properties of placed selected backfill, general fill and drainage material must conform to Table C213.2.

Chemical Properties of Backfill Material

Property	Test Method	Requirement
pH	TfNSW T123	≥ 5.5
Sulphates (expressed as SO ₄)	TfNSW T1011	≤ 1,000 mg/L
Chlorides	TfNSW T1010	≤ 200 mg/L

Table C213.2 – Chemical Properties of Fill and Drainage Material

No filling, including selected backfill, shall be placed against structures, retaining walls, headwalls or wingwalls within twenty one (21) days after placing of the concrete, unless the walls are effectively supported by struts to the satisfaction of the TRC Representative and/or the Developer's Representative (for Developer Infrastructure Works), or when the Constructor can demonstrate that 80% of the design strength of the concrete has been achieved.

Time of Placement

C213.26 TREATMENT AT WEEPHOLES

Drainage adjacent to weepholes shall be provided by either a layer of broken stone or river gravel consisting of clean, hard, durable particles graded from 50mm to 10mm such that:

Grading

- (a) The maximum particle dimension shall not exceed 50mm; and
- (b) No more than 5% by mass shall pass the 9.5mm A.S. sieve.

The broken stone or river gravel shall be continuous in the line of the weepholes, extend at least 300mm horizontally into the fill and extend at least 450mm vertically above the level of the weepholes. The drainage material shall be wrapped in geotextile.

Extent

Alternatively, the Constructor may provide a synthetic membrane of equivalent drainage characteristics at no extra cost to TRC. It shall be stored and installed in accordance with Manufacturer's instructions. The use of a synthetic membrane shall be subject to approval from the TRC Representative.

Synthetic Membrane

C213.27 FILL ADJACENT TO DRAINAGE AND BRIDGE STRUCTURES

Selected backfill must conform to the requirements shown in Table C213.3, and must be capable of achieving the relative compaction specified in Clause C213.30.

Selected Backfill Properties

Property	Test Method	Requirement
Particle size distribution:	TfNSW T106, T107 ⁽¹⁾	
Percentage passing A.S. Sieve (by mass)		
53 mm		100%
37.5 mm		> 60%
2.36 mm		< 50%
75 µm		< 15%
Coefficient of uniformity ⁽²⁾	TfNSW T106, T107 ⁽¹⁾	≥ 5
Plasticity Index	TfNSW T108, T109	≤ 15

⁽¹⁾ After pretreatment in accordance with Test Method TfNSW T102.

(2) *Coefficient of uniformity = D_{60}/D_{10} , where D_{60} and D_{10} are the equivalent sieve sizes in mm which 60% and 10% of the selected backfill passes respectively, as interpolated from particle size distribution curve*

Table C213.3 – Selected Backfill Material Properties

General fill must conform to the requirements shown in Table C213.4 and must be capable of achieving the relative compaction specified in Clause C213.30.

**General Fill
Properties**

Property	Test Method	Requirement
Maximum particle dimension	TfNSW T280	200 mm
Particle size distribution:	TfNSW T106	
Percentage passing A.S. Sieve (by mass)		
37.5 mm		> 60%
Coefficient of uniformity ⁽¹⁾	TfNSW T106, T107)	≥ 5

(1) *Coefficient of uniformity = D_{60}/D_{10} , where D_{60} and D_{10} are the equivalent sieve sizes in mm which 60% and 10% of the general backfill passes respectively, as interpolated from particle size distribution curve.*

Table C213.4 – General Fill Material Properties

Drainage zone material must be clean, graded, hard and durable, of either crushed stone or river gravel, conforming to the requirements shown in Table C213.5.

**Drainage Zone
Material
Properties**

Property	Test Method	Requirement
Particle size distribution:	TfNSW T106	
Percentage passing A.S. Sieve (by mass)		
53 mm		100%
9.5 mm		< 5%

Table C213.5 – Drainage Zone Material Properties

Selected backfill shall be placed adjacent to structures in accordance with Table C213.6.

Quality

Structure Type	Selected Backfill	
	Width	Height
Bridge abutments	2m	H
Cast-in-place Box Culverts	H/3	H + 300mm
Corrugated Steel Pipes and Arches	0.5m	H + 500mm
Retaining Walls	H/3	H

Note: Where H = height of retained backfill

Table C213.6 - Selected Backfill, Width and Height

The selected backfill and general fill shall be placed in layers, with a maximum compacted thickness of 150mm and 300mm respectively. Layers shall be placed simultaneously on both sides of box culverts to avoid differential loading. Compaction shall start at the wall and proceed away from it, and shall meet the requirements of Clause C213.30.

Placement in Layers

The existing embankment slope behind the structure shall be cut in the form of successive horizontal terraces, each terrace being at least 1m in width, and the selected backfill shall be placed in accordance with Clause C213.20.

Horizontal Terraces

Where a bridge deck is being concreted adjacent to an integral abutment, no filling shall be placed against the abutment within 21 days after placing concrete in the bridge deck.

Adjacent to Concrete Deck

In the case of spill-through abutments, rocks shall not be dumped against the columns or retaining walls but shall be built up evenly by individual placement around or against such structures.

Spill through Abutments

In the case of framed structures, including integral bridges, embankments at both ends of the structure shall be brought up simultaneously, the difference between the levels of the embankments at the respective abutments, shall not exceed 500mm.

Framed Structures

C213.28 SPOIL

Spoil is surplus material from excavations from the Works site which is not required to complete the Works as specified or material from excavations required as part of the Works.

Definition

Where there is surplus material, the Constructor may propose to provide flatter batter slopes on embankments which have not been commenced, and/or direct that the excess material be used in the uniform widening of embankments, the surface of which shall be shaped so as to provide a tidy appearance and effective drainage. The surplus material shall be spread and compacted as specified in Clauses C213.20 and C213.30 for material in embankments.

Use in Embankments

Alternatively, spoil shall be disposed of in the manner and at locations approved by the TRC Representative and/or the Developer's Representative (for Developer Infrastructure Works) within the specified working area for the work or be removed and disposed of off site by the Constructor.

Disposal of Spoil

Where there is insufficient capacity to accommodate surplus spoil, the Constructor shall dispose of the material at a Licensed waste disposal facility at the Constructor's cost.

C213.29 BORROW

The Constructor may be required to borrow material where there is insufficient suitable material within the Works site.

Where borrow material is required to complete the Works, the location of borrow sites shall be as approved by the TRC Representative and/or the Developer's Representative (for Developer Infrastructure Works). The edges of borrow sites shall be no closer than 3m from any fence line, or edge of excavation or embankment. Adequate clearance shall be provided for the construction of catch drains. Borrow sites shall have drainage outlets acceptable to the TRC Representative and/or the Developer's Representative (for Developer Infrastructure Works), cut batter slopes not steeper than 4H to 1V and shall be left by the Constructor in a tidy and safe condition.

Borrow to be Authorized

Borrow Site Characteristics

For borrow within the defined working area for the Works, site preparation shall be in accordance with C212 - *Clearing and Grubbing* and Clause C213.08. Restoration of borrow sites shall be carried out in accordance with C273 – *Landscaping*.

Site Preparation and Restoration

If borrow material is obtained by uniformly widening a cutting, the requirements of Clauses C213.10, C213.11 and C213.12 as to the redetermination of batter slopes, the

Widening of

trimming of batters and the compaction of floors of cuttings respectively shall apply to the borrow area.

Cutting

The Constructor shall be responsible for obtaining any permits required for entry on land and for the payment of any royalty for such borrow material. The Constructor shall also comply with any requirements of the EP&A Act, TRC, land owners, the Rural Lands Protection Board and the NSW Soil Conservation Service, as appropriate.

Constructor Responsibility

COMPACTION AND QUALITY CONTROL

C213.30 COMPACTION AND MOISTURE REQUIREMENTS

In areas listed below, all layers shall be uniformly compacted to not less than the relative compaction specified before the next layer is commenced. Each layer of material shall be trimmed prior to and during compaction to avoid bridging over low areas. A smooth surface shall be presented at the top of each layer.

Trimming and Compaction

Spoil (including unsuitable material) shall be compacted to provide a relative compaction of not less than 95% as determined by AS 1289.5.4.1 for standard compactive effort.

95% Compaction Requirements

The following areas shall be compacted to provide a relative compaction of not less than 98% as determined by AS 1289.5.4.1 for modified compactive effort:

98% Compaction Requirements

- Each layer of material replacing unsuitable material as detailed in Clause C213.14.
- Each layer of material placed in embankments, up to 0.5m from the top of the pavement.
- The whole area on the floors of cuttings.
- Fill placed adjacent to any other structures not listed in C213.27 up to 1.0m from the top of pavement.
- Material in unsealed verges and within medians up to the level at which topsoil is placed.
- Foundations for shallow embankments.
- Foundations other than shallow embankments.
- Each layer of the embankment within 0.5m from the top of pavement.
- Any areas of material of specified quality which may be shown on the approved design drawings or specified elsewhere behind kerbs and/or gutters or adjacent to rigid pavements.
- The fill material placed adjacent to structures as specified in Clauses C213.25 and C213.27 in each layer within 1m from the top of the pavement.

The SMZ shall be compacted in accordance with the approved design drawings or 100%, whichever is the greater, as determined by AS 1289.5.4.1 for standard compactive effort.

SMZ Compaction Requirements

At the time of compaction, the moisture content of the material shall be adjusted so as to permit the specified compaction to be attained at a moisture content which is within the range set out in Annexure C213A of the optimum moisture content as determined by AS 1289.5.1.1 or AS 1289.5.7.1. Material which becomes wetted up after placement shall not be compacted until it has dried out so that the moisture content is within this range. The drying process may be assisted by aeration by the use of hydrated or quick lime at the Constructor's cost. Alternatively, the Constructor may transport the wet material to a stockpile site for drying out and later use as fill material. The cost of transport to stockpile for drying out and later use shall be borne by the Constructor. If there is insufficient moisture in the material for it to be compacted as specified, water shall be added. The added water shall be applied uniformly and thoroughly mixed with

Moisture Content

Constructor's Cost for Drying and Wetting

the material until a homogeneous mixture is obtained. The cost of such wetting or drying the material to be compacted shall be borne by the Constructor.

Compaction shall be undertaken to obtain the specified relative compaction for the full depth of each layer in embankments and for the full width of the formation over the entire length of the work. Compaction shall be completed promptly to minimise the possibility of rain damage.

**Prompt
Compaction**

Any material placed by the Constructor that has attained the specified relative compaction but subsequently becomes wetted up so that the moisture content is greater than the apparent optimum, determined by AS 1289.5.7.1, shall be dried out and uniformly recompact to the required relative compaction in accordance with this Clause before the next layer of material is placed. Alternatively, the Constructor may remove the layer of wetted material to a stockpile site for drying and later re-use. The cost of the removal to stockpile, drying out and reincorporation of the wet material shall be borne by the Constructor.

**Moisture Content
above Optimum**

**Constructor's
Cost**

Hold Point

The Constructor shall submit to the TRC Representative and/or the Developer's Representative (for Developer Infrastructure Works) all test results verifying conformity of compaction and moisture content of all areas as defined by Clause C213.29.

Hold Point

Process Held: Placement of subsequent layers.

C213.31 TEST LOCATIONS

The specified compaction and moisture tests shall be taken at the random test locations established in each lot in accordance with the specified minimum testing frequency. Prior to testing the Constructor shall work the lot to ensure uniform moisture content and compaction of all material within the lot.

**Constructor to
Prepare Area**

The test(s) then taken shall be considered to represent the total volume of material placed within the lot.

**Test
Representation**

Where the TRC Representative considers that the material which is present has not achieved uniformity required by this Clause or Clause C213.20, further testing may be directed. The TRC Representative shall nominate the area(s) for additional testing.

Further Testing

If such testing confirms that material not conforming to the Specification is present, the cost of such tests shall be borne by the Constructor. The Constructor shall carry out remedial work as necessary to achieve conformance to the requirements of Clause C213.30.

**Constructor's
Cost**

C213.32 WIDENING OF FORMATION

Road shoulders and formation shall be widened to accommodate footpaths, safety barrier, streetlight plinths, emergency telephone bays and vehicle standing areas as shown on the approved design drawings.

**Provision for
Services**

The pavement layers for widenings shall be stepped as per the approved design drawings. In the absence of suitable detail each layer shall be stepped 300mm inside the underlying step or joint in accordance with TRC Standard Drawing RD002.

LIMITS AND TOLERANCES

C213.33 SUMMARY OF LIMITS AND TOLERANCES

The limits and tolerances applicable to the various clauses in this Specification are summarized in Table C213.7 below:

Item	Activity	Limits/Tolerances	Spec Clause
1	Batter Slopes		
	a) Excavation	± 300mm	C213.11
	b) Embankment	± 300mm	C213.21
2	Floors		
	Floor of Cutting	Parallel to the designed grade line and 0mm and -50mm of the designed floor level.	C213.13
3	Tops of Embankments		
	Trimming	Parallel to the designed grade line, +10mm or -40mm of the levels specified.	C213.23
4	Compaction		
	Spoil (including unsuitable material)	Relative compaction > 92% (modified)	C213.30
	<ul style="list-style-type: none"> • Each layer of material replacing unsuitable material as detailed in Clause C213.15. • Each layer of material placed in embankments, up to 0.5m from the top of the pavement. • The whole area on the floors of cuttings. • Fill placed adjacent to structures up to 1.0m from the top of pavement. • Material in unsealed verges and within medians up to the level at which topsoil is placed. • Foundations for shallow embankments. • Foundations other than shallow embankments. • Each layer of the embankment within 0.5m from the top of pavement. • Any areas of material of specified quality which may be shown on the approved design drawings or specified elsewhere behind kerbs and/or gutters or adjacent to rigid pavements. • The fill material placed adjacent to structures as specified in Clauses C213.25 and C213.27 in each layer within 1m from the top of the pavement 	Relative compaction > 98% (standard)	C213.30
	SMZ	Relative compaction > 100% (standard)	C213.30
4	Selected Material		
	Selected Material	Annexure C213A	C213A

Note: Plus (+) is towards the roadway/surface and minus (-) is away from the roadway/surface. Tolerances are measured at right angles to design surfaces.

Table C213.7 - Summary of Limits and Tolerances

ANNEXURE C213A
EARTHWORKS - PROJECT SPECIFIC INFORMATION

To be completed by the Designer for approval in conjunction with the Construction Certificate

Clause	Description	Value		
C213.07	The depth below natural surface up to which the removal and measurement of topsoil shall apply:			
	a) Cutting areas	_____mm		
	b) Embankment areas	_____mm		
C213.13	Minimum CBR value in cutting floors used for design of pavement	_____%		
C213.20	Requirements of material in foundations for shallow embankments: Moisture Content - within the range of _____% to _____% of optimum.			
C213.23	Selected Material Zone (SMZ)			
	Material within each zone shall have a CBR value of not less than the following, under the nominated test conditions:			
	Location			
	SMZ	Minimum CBR Value	Depth (mm)	Nominated Soaking Period (Days)
	(a) Material below SMZ to 1.0m from top of pavement			
(b) Construction tolerances for SMZ are +_____mm or - _____mm of the designed grade and crossfall.				
C213.23	Moisture Content of material placed in embankments:			
	a) Material in upper zones of formation:- within the range of _____% to _____% of optimum.			
	(b) All other embankment material:- within the range of _____% to _____% of optimum.			
C213.29				

ANNEXURE C213B SETTING OUT OF EARTHWORKS

Before earthworks operations commence and after survey controls are in place, batter profiles shall be established by the Constructor and the necessary pegs driven at 25m intervals or at each cross section shown on the approved design drawings, whichever is the lesser. The chainage/station, offset from control line and slope distance to finished surface level, shall be clearly marked on each peg.

Batter Profiles

The batter profiles shall be repositioned by the Constructor at each change in the slope of the batter and at intervals of not more than 5m of vertical height.

Profile Location

All pegs and batter profiles shall be maintained in their correct positions. They shall be removed by the Constructor on completion of the Works.

Retention and Removal of Pegs

The foregoing shall be the minimum requirement. Additional pegs and profiles may be required to suit the Constructor. These shall not be painted with the same colours used for the specified setting out pegs and stakes.

Additional Pegs

The position and extent of all transitions from cuttings to embankments and foundations for shallow embankments shall be marked with clearly labelled stakes in accordance with Clauses C213.16 and C213.20.

Transitions Cuttings/ Embankments

Before earthworks operations commence for machine control setout, the Constructor shall confirm with the TRC Representative and/or the Developer's Representative (for Developer Infrastructure Works) that the footprint of the earthworks formation is in accordance with the approved design drawings. Where errors have been identified for work undertaken by machine control, all costs for rectification shall be borne by the Constructor.

Machine Control Setout

This is the last page of the document